

La bellezza e la forza del legno massello per una cucina dal sapore classico che può essere interpretata in chiave contemporanea. Romantica per natura, Agnese è la cucina della tradizione, creata da mani sapienti che curano ogni minimo dettaglio, ma che non rinuncia alla modernità degli accessori e dei materiali che la arricchiscono, donando una ottima praticità di uso. Le finiture decapè oppure a poro aperto, disponibili in sei calde tonalità, sono state pensate per offrire una gamma che saprà esaltare ogni vostro progetto.



The beauty and strength of solid wood for a kitchen with a classical feel that can also be used in a contemporary way. Romantic by nature and crafted with extreme precision by skilled hands, Agnese is the traditional kitchen that nevertheless makes use of completely modern and extremely practical accessories and materials. The open pore or pickled finishes, available in six warm tones, are designed to offer a range that suits all design requirements.

Naturalmente romantica

# Agnese



## LUBE ECOLOGIC

IL GRUPPO LUBE HA SCELTO DI UTILIZZARE PER I COMPONENTI COSTITUENTI LE STRUTTURE DELLE CUCINE SOLO MATERIALE A BASSISSIMA EMISSIONE DI FORMALDEIDE: CONFORMI ALLO STANDARD F4STELLE SECONDO LA NORMA JIS, CERTIFICATO DAL MINISTERO GIAPPONESE, IL PIU' SEVERO IN MERITO ALLE NORMATIVE DI SALVAGUARDIA AMBIENTALE.

Regarding the production of its kitchen structure components, lube group has decided to only use materials featuring very low formaldehyde emissions complying with the 4-star standard, as defined by the jis regulation. This standard is certified by the japanese government-the most rigorous when it comes to environmental protection.

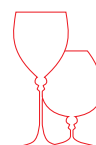

cod. **605**

**SP. 24 MM**

*Agnese*

## CARATTERISTICHE TECNICHE

**ANTE** intaliate in massello di frassino sp. mm 24 con bugna in massello di frassino nei colori: laccato bianco camelia a poro aperto (opz.606), argilla decapè grigio a poro aperto (opz.599), grigio fumo decapè bianco a poro aperto (opz.603), bianco assoluto a poro aperto (opz.609), celeste decapè a poro aperto (opz.607)

**ANTE VETRO** di serie: telaio in massello di frassino sp. mm 24 con inglesina colore laccato bianco camelia a poro aperto (opz.606I), argilla decapè grigio a poro aperto (opz.599I), grigio fumo decapè bianco a poro aperto (opz.603I), bianco assoluto a poro aperto (opz.609I), celeste decapè a poro aperto (opz.607I), con vetro antico "F" spessore mm 4

a richiesta: telaio in massello di frassino sp. mm 24 colore laccato bianco camelia a poro aperto (opz.606), argilla decapè grigio a poro aperto (opz.599), grigio fumo decapè bianco a poro aperto (opz.603), bianco assoluto a poro aperto (opz.609), celeste decapè a poro aperto (opz.607), con vetro rilegato serigrafato finta tela

**MANIGLIE** di serie: 605 finitura argento anticato passo mm 96

a richiesta:

155 finitura argento anticato passo mm 96

606 finitura argento anticato passo mm 96

435 pomo finitura argento anticato

638 finitura ottone anticato passo mm 96

157 finitura ottone anticato passo mm 96

430 pomo finitura ottone antico

610 pomo ottone antico con formella in ceramica realizzata e dipinta a mano in 4 colori

251 finitura nichel nero satinato lucido passo mm 160 per anta L 15 passo mm 96

282C finitura cromo con swarovski passo mm 128 per anta L 15 pomo finitura cromo con swarovski 282CP

283N finitura nichel lucido con swarovski passo mm 128

per anta L 15 pomo finitura nichel lucido con swarovski 283NP

247 finitura nichel lucido con swarovski centrali passo mm 160

per anta L 15 maniglia finitura nichel lucido con swarovski centrali 247/1

224 finitura argento antico passo mm 128

per anta L 15 pomo finitura argento antico 224P

439 finitura cromo con parte centrale satinata passo mm 128

per anta L 15 pomo finitura satinata 439P

521 finitura cromo passo mm 128

per anta L 15 pomo finitura cromo 244P

522 laterali finitura cromo con interno satinato passo mm 160 per anta L 15 passo mm 64

523 finitura cromo con inserto corda passo mm 160

per anta L 15 passo mm 64

524 finitura cromo/satinata passo mm 160

per anta L 15 pomo finitura cromo 524P passo mm 16

**STRUTTURE** ANTA: laccato bianco camelia a poro aperto (opz.606) argilla decapè grigio (opz.599) grigio fumo decapè bianco a poro aperto (opz.603) nobilitato bianco camelia (opz.606) schiena e ripiano avorio (opz.930) ANTA: bianco assoluto a poro aperto (opz.609) nobilitato bianco (opz.001) schiena e ripiano bianco (opz.001) ANTA: celeste decapè a poro aperto (opz.607) nobilitato celeste agnese (opz.607) schiena e ripiano avorio (opz.930)

a richiesta: nobilitato perla d'oriente (opz.940) schiena e ripiano avorio (opz.930)

**MENSOLE** di serie: altezza cm 3,8 in laminato bianco camelia (opz.606), bianco (opz.001), perla d'oriente (opz.940), celeste agnese (opz.607), noce guarnieri (opz.050) a richiesta: impiallacciata altezza cm 3,8 finiture come ante

**ZOCCOLI** di serie: altezza cm 15 in pvc ricoperti in melamina colore bianco camelia (opz.606), argilla decapè (opz.599), grigio fumo decapè (opz.603), bianco (opz.001), celeste agnese (opz.607), noce guarnieri (opz.050), con guarnizione in gomma a richiesta: altezza cm 15 alluminio liscio finitura brill (opz.412), vedi maggiorazioni accessori pag.177





## TECHNICAL FEATURES

<b>DOORS</b>	<p>solid ash frame Th. 24 mm with solid ash raised panel in the following finishes: open pore camellia white lacquer (opt. 606), open pore pickled clay grey (opt. 599), open pore pickled white smoke grey (opt. 603), open pore absolute white (opt. 609),</p>
<b>GLASS DOORS</b>	<p><b>standard:</b> solid ash frame Th. 24 mm with glass panels in open pore camellia white lacquer finish (opt. 606), open pore pickled clay grey (opt. 599), open pore pickled white smoke grey (opt. 603), open pore absolute white (opt. 609), open pore pickled sky blue (opt. 607), with antique glass "F" Th. 4 mm</p> <p><b>on request:</b> solid ash frame Th. 24 mm in open pore camellia white lacquer finish (opt. 606), open pore pickled clay grey (opt. 599), open pore pickled white smoke grey (opt. 603), open pore absolute white (opt. 609), open pore pickled sky blue (opt. 607), with false canvas effect printed burnished</p>
<b>HANDLES</b>	<p><b>standard:</b> 605 antique silver finish centre-to-centre distance 96 mm</p> <p><b>on request:</b></p> <ul style="list-style-type: none"> <li>155 antique silver finish centre-to-centre distance 96 mm</li> <li>606 antique silver finish centre-to-centre distance 96 mm</li> <li>435 knob hole with antique silver finish</li> <li>638 antique brass finish centre-to-centre distance 96 mm</li> <li>157 antique brass finish centre-to-centre distance 96 mm</li> <li>430 knob hole with antique brass finish</li> <li>610 knob hole with antique brass finish and handmade, hand-painted 4-colour ceramic tile</li> <li>251 polished satin-finish black nickel finish centre-to-centre distance 160 mm for W 15 door centre-to-centre distance 96 mm</li> <li>282C chrome finish with Swarovski crystals centre-to-centre distance 128 mm</li> <li>for door W 15 chrome finish knob hole with Swarovski crystals 282CP</li> <li>283N polished nickel finish with Swarovski crystals centre-to-centre distance 128 mm</li> <li>for door W 15 polished nickel finish knob hole with Swarovski crystals 283NP</li> <li>247 polished nickel finish with central Swarovski crystals centre-to-centre distance 160 mm</li> <li>for door W 15 polished nickel finish knob hole with central Swarovski crystals 247/1</li> <li>224 antique silver finish centre-to-centre distance 128 mm</li> <li>for door W 15 antique silver finish knob hole 224P</li> <li>439 chrome finish with satin finish central part centre-to-centre distance 128 mm</li> <li>for door W 15 satin finish knob hole 439P</li> <li>521 chrome finish centre-to-centre distance 128 mm</li> <li>for door W 15 chrome finish knob hole 224P</li> <li>522 chrome finish on sides with satin finish on inside centre-to-centre distance 160 mm</li> <li>for door W 15 centre-to-centre distance 64 mm 523 chrome finish with rope insert centre-to-centre distance 160 mm</li> <li>for door W 15 centre-to-centre distance 64 mm</li> <li>524 chrome/satin finish centre-to-centre distance 160 mm</li> <li>for door W 15 chrome finish knob hole 524P centre-to-centre distance 16 mm</li> </ul>
<b>CARCASSES</b>	<p><b>DOOR:</b> open pore camellia white lacquer (opt. 606), pickled clay grey (opt. 599), open pore pickled white smoke grey (opt. 603) melamine-coated camellia white (opt. 606), ivory back panel and shelf (opt. 930)</p> <p><b>DOOR:</b> open pore absolute white (opt. 609) melamine-coated white (opt. 001), white back panel and shelf (opt. 001)</p> <p><b>DOOR:</b> open pore pickled sky blue (opt. 607) melamine-coated agnese blue (opt. 607), ivory back panel and shelf (opt. 930)</p> <p><b>on request:</b> melamine-coated oriental pearl (opt. 940), ivory back panel and shelf (opt. 930)</p>
<b>SHELVES</b>	<p><b>standard:</b> height 3.8 cm in camellia white laminate (opt. 606), white (opt. 001), oriental pearl (opt. 940), agnese blue (opt. 607), guarneri walnut (opt. 050)</p> <p><b>on request:</b> height 3.8 cm, veneered with same finish as doors</p>
<b>PLINTHS</b>	<p><b>standard:</b> height 15 cm, melamine-coated PVC in camellia white (opt. 606), pickled clay grey (opt. 599), pickled white smoke grey (opt. 603), white (opt. 001), with rubber seals, agnese blue (opt. 607), guarneri walnut (opt. 050)</p> <p><b>on request:</b> height 15 cm, shooth aluminium with brill finish (opt.412), see surcharges for accessories page 177</p>

cod. **605**

**SP. 24 MM**

ante doors

*Agnese*



anta bianco camelia  
a poro aperto (opt.606)  
open pore camellia white  
door (opt. 606)



frontale cassetto  
drawer front panel



frontale cestone  
deep drawer front  
panel



anta argilla decapè  
grigio a poro aperto  
(opt.599)  
open pore pickled clay  
grey door (opt. 599)



frontale cassetto  
drawer front panel



frontale cestone  
deep drawer front  
panel

di serie: ante con vetro antico "F"

standard: doors with antique glass "F"



telaio bianco camelia  
a poro aperto (opt.6061)  
open pore camellia white  
frame (opt. 6061)



telaio cestone  
deep drawer frame



telaio argilla decapè  
grigio a poro aperto  
(opt.5991)  
open pore pickled clay  
grey frame (opt. 5991)



telaio cestone  
deep drawer frame

a richiesta: ante con vetro rilegato serigrafato finta tela

on request: doors with false canvas effect printed burnished glass



telaio bianco camelia  
a poro aperto (opt.606)  
open pore camellia white  
frame (opt. 606)



telaio cestone  
deep drawer frame



telaio argilla decapè  
grigio a poro aperto  
(opt.599)  
open pore pickled clay  
grey frame (opt. 599)



telaio cestone  
deep drawer frame

cod. **605**

**SP. 24 MM**

ante doors

*Agnese*



**anta grigio fumo  
decapè bianco a poro  
aperto (opz.603)**  
open pore pickled white  
smoke grey door  
(opt. 603)



**frontale cassetto**  
drawer front panel



**frontale cestone**  
deep drawer front  
panel



**anta bianco assoluto  
a poro aperto (opz.609)**  
open pore absolute  
white door (opt. 609)



**frontale cassetto**  
drawer front panel



**frontale cestone**  
deep drawer front  
panel

di serie: ante con vetro antico "F"

standard: doors with antique glass "F"



**telaio grigio fumo  
decapè bianco a poro  
aperto (opz.603I)**  
open pore pickled white  
smoke grey frame  
(opt. 603I)



**telaio cestone**  
deep drawer frame



**telaio bianco assoluto  
a poro aperto (opz.609I)**  
open pore absolute  
white frame (opt. 609I)



**telaio cestone**  
deep drawer frame

a richiesta: ante con vetro rilegato serigrafato finta tela

on request: doors with false canvas effect printed burnished glass



**telaio grigio fumo  
decapè bianco a poro  
aperto (opz.603)**  
open pore pickled white  
smoke grey frame  
(opt. 603)



**telaio cestone**  
deep drawer frame



**telaio bianco assoluto  
a poro aperto (opz.609)**  
open pore absolute  
white frame (opt. 609)



**telaio cestone**  
deep drawer frame

cod. **605**

**SP. 24 MM**

*Agnese*

ante doors



anta celeste decapè  
a poro aperto (opz.607)  
open pore pickled sky blue  
door (opt. 607)



frontale cassetto  
drawer front panel



frontale cestone  
deep drawer front  
panel

di serie: ante con vetro antico "F"  
standard: doors with antique glass "F"



telaio celeste decapè  
a poro aperto (opz.6071)  
open pore pickled sky  
blue frame (opt. 6071)



telaio cestone  
deep drawer frame

a richiesta: ante con vetro rilegato serigrafato finta tela  
on request: doors with false canvas effect printed burnished glass



telaio celeste decapè  
a poro aperto (opz.607)  
open pore pickled sky  
blue frame (opt. 607)



telaio cestone  
deep drawer frame

cod. **605**

**SP. 24 MM**

ante con formella  
doors with tile

*Agnese*



anta bianco camelia a poro aperto (opz. 606F) con 3 formelle 8x8 in ceramica realizzate e dipinte a mano colore bianco disponibile per ante 131,7x44,6 e 131,7x59,6

open pore camellia white door (opt. 606F) with 3 handmade, hand-painted white 8x8 ceramic tiles available for doors measuring 131.7 x 44.6 and 131.7 x 59.6



anta bianco camelia a poro aperto (opz. 606F) con 1 formella 8x8 in ceramica realizzate e dipinte a mano colore bianco disponibile per ante 71,7x44,6 e 71,7x59,6

open pore camellia white door (opt. 606F) with 1 handmade, hand-painted white 8x8 ceramic tile available for doors measuring 71.7 x 44.6 and 71.7 x 59.6



frontale bianco camelia a poro aperto (opz. 606F) con 5 formelle 4x4 in ceramica realizzate e dipinte a mano colore bianco disponibile per anta ribalta e cestone 35,7x89,6

open pore camellia white front panel (opt. 606F) with 5 handmade, hand-painted white 4x4 ceramic tiles available for flap door and deep drawer measuring 35.7 x 89.6



frontale bianco camelia a poro aperto (opz. 606F) con 3 formelle 4x4 in ceramica realizzate e dipinte a mano colore bianco disponibile per anta ribalta e cestone 35,7x59,6

open pore camellia white front panel (opt. 606F) with 3 handmade, hand-painted white 4x4 ceramic tiles available for flap door and deep drawer measuring 35.7 x 59.6



frontale bianco camelia a poro aperto (opz. 606F) con 1 formella 4x4 in ceramica realizzate e dipinte a mano colore bianco disponibile per anta ribalta e cestone 35,7x44,6

open pore camellia white front panel (opt. 606F) with 1 handmade, hand-painted white 4x4 ceramic tile available for flap door and deep drawer measuring 35.7 x 44.6



anta argilla decapè grigio (opz. 599F) con 3 formelle 8x8 in ceramica realizzate e dipinte a mano colore bianco disponibile per ante 131,7x44,6 e 131,7x59,6

pickled clay grey door (opt. 599F) with 3 handmade, hand-painted white 8x8 ceramic tiles available for doors measuring 131.7 x 44.6 and 131.7 x 59.6



anta argilla decapè grigio (opz. 599F) con 1 formella 8x8 in ceramica realizzate e dipinte a mano colore bianco disponibile per ante 71,7x44,6 e 71,7x59,6

pickled clay grey door (opt. 599F) with 1 handmade, hand-painted white 8x8 ceramic tile available for doors measuring 71.7 x 44.6 and 71.7 x 59.6



frontale argilla decapè grigio (opz. 599F) con 5 formelle 4x4 in ceramica realizzate e dipinte a mano colore bianco disponibile per anta ribalta e cestone 35,7x89,6

walnut-stained front panel (opt. 604F) with 5 handmade, hand-painted yellow ochre 4x4 ceramic tiles available for flap door and deep drawer measuring 35.7 x 89.6



frontale argilla decapè grigio (opz. 599F) con 3 formelle 4x4 in ceramica realizzate e dipinte a mano colore bianco disponibile per anta ribalta e cestone 35,7x59,6

walnut-stained front panel (opt. 604F) with 3 handmade, hand-painted yellow ochre 4x4 ceramic tiles available for flap door and deep drawer measuring 35.7 x 59.6



frontale argilla decapè grigio (opz. 599F) con 1 formella 4x4 in ceramica realizzate e dipinte a mano colore bianco disponibile per anta ribalta e cestone 35,7x44,6

walnut-stained front panel (opt. 604F) with 1 handmade, hand-painted yellow ochre 4x4 ceramic tile available for flap door and deep drawer measuring 35.7 x 44.6



cod. **605**

**SP. 24 MM**

ante con formella  
doors with tile

*Agnese*



anta grigio fumo decapè bianco a poro aperto (opz. 603F) con 3 formelle 8x8 in ceramica realizzate e dipinte a mano colore grigio disponibile per ante 131,7x44,6 e 131,7x59,6

open pore pickeld white smoke grey door (opt. 603F) with 3 handmade, hand-painted grey 8x8 ceramic tiles available for doors measuring 131.7 x 44.6 and 131.7 x 59.6



anta grigio fumo decapè bianco a poro aperto (opz. 603F) con 1 formella 8x8 in ceramica realizzate e dipinte a mano colore grigio disponibile per ante 71,7x44,6 e 71,7x59,6

open pore pickeld white smoke grey door (opt. 603F) with 1 handmade, hand-painted grey 8x8 ceramic tile available for doors measuring 71.7 x 44.6 and 71.7 x 59.6



frontale grigio fumo decapè bianco a poro aperto (opz. 603F) con 5 formelle 4x4 in ceramica realizzate e dipinte a mano colore grigio disponibile per anta ribalta e cestone 35,7x89,6

open pore pickled white smoke grey front panel (opt. 603F) with 5 handmade, hand-painted grey 4x4 ceramic tiles available for flap door and deep drawer measuring 35.7 x 89.6



frontale grigio fumo decapè bianco a poro aperto (opz. 603F) con 3 formelle 4x4 in ceramica realizzate e dipinte a mano colore grigio disponibile per anta ribalta e cestone 35,7x59,6

open pore pickled white smoke grey front panel (opt. 603F) with 3 handmade, hand-painted grey 4x4 ceramic tiles available for flap door and deep drawer measuring 35.7 x 59.6



frontale grigio fumo decapè bianco a poro aperto (opz. 603F) con 1 formella 4x4 in ceramica realizzate e dipinte a mano colore grigio disponibile per anta ribalta e cestone 35,7x44,6

open pore pickled white smoke grey front panel (opt. 603F) with 1 handmade, hand-painted grey 4x4 ceramic tile available for flap door and deep drawer measuring 35.7 x 44.6



anta bianco assoluto a poro aperto (opz. 609F) con 3 formelle 8x8 in ceramica realizzate e dipinte a mano colore bianco disponibile per ante 131,7x44,6 e 131,7x59,6

open pore absolute white door (opt. 609F) with 3 handmade, hand-painted white 8x8 ceramic tiles available for doors measuring 131.7 x 44.6 and 131.7 x 59.6



anta bianco assoluto a poro aperto (opz. 609F) con 1 formella 8x8 in ceramica realizzate e dipinte a mano colore bianco disponibile per ante 71,7x44,6 e 71,7x59,6

open pore absolute white door (opt. 609F) with 1 handmade, hand-painted white 8x8 ceramic tile available for doors measuring 71.7 x 44.6 and 71.7 x 59.6



frontale bianco assoluto a poro aperto (opz. 609F) con 5 formelle 4x4 in ceramica realizzate e dipinte a mano colore bianco disponibile per anta ribalta e cestone 35,7x89,6

open pore absolute white front panel (opt. 609F) with 5 handmade, hand-painted white 4x4 ceramic tiles available for flap door and deep drawer measuring 35.7 x 89.6



frontale bianco assoluto a poro aperto (opz. 609F) con 3 formelle 4x4 in ceramica realizzate e dipinte a mano colore bianco disponibile per anta ribalta e cestone 35,7x59,6

open pore absolute white front panel (opt. 609F) with 3 handmade, hand-painted white 4x4 ceramic tiles available for flap door and deep drawer measuring 35.7 x 59.6



frontale bianco assoluto a poro aperto (opz. 609F) con 1 formella 4x4 in ceramica realizzate e dipinte a mano colore bianco disponibile per anta ribalta e cestone 35,7x44,6

open pore absolute white front panel (opt. 609F) with 1 handmade, hand-painted white 4x4 ceramic tile available for flap door and deep drawer measuring 35.7 x 44.6



cod. **605**

**SP. 24 MM**

ante con formella  
doors with tile

*Agnese*



anta celeste decapè (opz. 607F)  
con 3 formelle 8x8 in ceramica realizzate  
e dipinte a mano colore celeste disponibile  
per ante 131,7x44,6 e 131,7x59,6

pickled sky blue door (opt. 607F) with 3  
handmade, hand-painted sky blue 8x8 ceramic  
tiles available for doors measuring 131.7 x 44.6  
and 131.7 x 59.6



anta celeste decapè (opz. 607F)  
con 1 formella 8x8 in ceramica realizzate  
e dipinte a mano colore celeste disponibile  
per ante 71,7x44,6 e 71,7x59,6

pickled sky blue door (opt. 607F) with  
1 handmade, hand-painted sky blue 8x8  
ceramic tile available for doors measuring  
71.7 x 44.6 and 71.7 x 59.6



frontale celeste decapè (opz. 607F)  
con 5 formelle 4x4 in ceramica realizzate e dipinte  
a mano colore celeste disponibile per anta  
ribalta e cestone 35,7x89,6

pickled sky blue front  
panel (opt. 607F) with 5 handmade, hand-painted  
sky blue 4x4 ceramic tiles available for flap door  
and deep drawer measuring 35.7 x 89.6



frontale celeste decapè (opz. 607F)  
con 3 formelle 4x4 in ceramica realizzate e dipinte  
a mano colore celeste disponibile per anta  
ribalta e cestone 35,7x59,6

pickled sky blue front  
panel (opt. 607F) with 3 handmade, hand-painted  
sky blue 4x4 ceramic tiles available for flap door  
and deep drawer measuring 35.7 x 59.6



frontale celeste decapè (opz. 607F)  
con 1 formella 4x4 in ceramica realizzate e dipinte  
a mano colore celeste disponibile per anta  
ribalta e cestone 35,7x44,6

pickled sky blue front  
panel (opt. 607F) with 1 handmade, hand-painted  
sky blue 4x4 ceramic tile available for flap door  
and deep drawer measuring 35.7 x 44.6



cod. **605**

**elementi da 15 con piastrelle 10x10 n.b.: per prezzi vedi pag.162**

15 cm elements with 10x10 tiles - Note: for prices see page 162

*Agnese*

Serie: VERONA **NEW**

Range: VERONA **NEW**



telaio bianco camelia  
a poro aperto con piastrelle  
rosso persia  
open pore camellia white  
frame with persian red tiles



telaio bianco assoluto  
a poro aperto con piastrelle  
rosa antico  
open pore absolute white  
frame with antique pink tiles



rosso persia  
(opz.235)  
persian red



giallo reale  
(opz.232)  
royal yellow



rosa antico  
(opz.230)  
antique pink



botticino  
(opz.240)  
botticino



telaio grigio fumo decapè  
bianco a poro aperto con  
piastrelle bianco antico  
open pore pickled white smoke  
grey frame with antique white tiles



telaio celeste decapè  
con piastrelle bianco antico  
pickled sky blue frame with  
antique white tiles

Serie: ANTIQUA

Range: ANTIQUA



bianco antico  
opaco (opz.011)  
matt antique white



bianco lucido  
(opz.021)  
glossy white



gres beige  
(opz.015)  
beige stoneware

Serie: SASSI DEL PIAVE

Range: SASSI DEL PIAVE



botticino  
(opz.120)  
botticino



travertino noce  
(opz.125)  
walnut travertine



scabas  
(opz.110)  
scabas



giallo dorè  
(opz.112)  
golden yellow



travertino chiaro  
(opz.127)  
light travertine



telaio argilla decapè grigio  
con piastrelle travertino chiaro  
pickled clay grey frame with  
light travertine tiles

cod. **605**

**elementi da 15 con fresata e piastrina n.b.: per prezzi vedi pag.164**

15 cm elements with groove and stud - Note: for prices see page 164

*Agnese*



anta bianco camelia a poro aperto con piastrina finitura argento e pomo (opz.435)  
open pore camellia white door with silver-finished plate and knob hole (opt. 435)



anta argilla decapè grigio con piastrina finitura argento e pomo (opz.435)  
pickled clay grey door with silver-finished plate and knob hole (opt. 435)



anta grigio fumo decapè bianco con piastrina finitura argento e pomo (opz.435)  
pickled white smoke grey door with silver-finished plate and knob hole (opt. 435)



anta bianco assoluto con piastrina finitura argento e pomo (opz.435)  
absolute white door with silver-finished plate and knob hole (opt. 435)



anta celeste decapè con piastrina finitura argento e pomo (opz.435)  
pickled sky blue door with silver-finished plate and knob hole (opt. 435)



anta bianco camelia a poro aperto con piastrina finitura ottone e pomo (opz.430)  
open pore camellia white door with brass-finished plate and knob hole (opt. 430)



anta argilla decapè grigio con piastrina finitura ottone e pomo (opz.430)  
pickled clay grey door with brass-finished plate and knob hole (opt. 430)



anta grigio fumo decapè bianco con piastrina finitura ottone e pomo (opz.430)  
pickled white smoke grey door with brass-finished plate and knob hole (opt. 430)



anta bianco assoluto con piastrina finitura ottone e pomo (opz.430)  
absolute white door with brass-finished plate and knob hole (opt. 430)

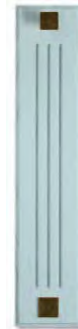

anta celeste decapè con piastrina finitura ottone e pomo (opz.430)  
pickled sky blue door with brass-finished plate and knob hole (opt. 430)



anta bianco camelia a poro aperto con piastrina finitura ottone e pomo in ceramica bianco (opz.610B)  
open pore camellia white door with brass-finished plate and white ceramic knob hole (opt. 610B)



anta argilla decapè grigio con piastrina finitura ottone e pomo in ceramica bianco (opz.610B)  
pickled clay grey door with brass-finished plate and white ceramic knob (opt. 610B)



anta grigio fumo decapè bianco con piastrina finitura ottone e pomo in ceramica grigio (opz.610R)  
pickled white smoke grey door with brass-finished plate and grey ceramic knob hole (opt. 610R)



anta bianco assoluto con piastrina finitura ottone e pomo in ceramica bianco (opz.610B)  
absolute white door with brass-finished plate and white ceramic knob hole (opt. 610B)



anta celeste decapè con piastrina finitura ottone e pomo in ceramica celeste (opz.610C)  
pickled sky blue door with brass-finished plate and sky blue ceramic knob hole (opt. 610C)

## MANIGLIE HANDLES

# Agnese

### DI SERIE STANDARD



Maniglia 605 finitura argento anticato  
passo 96 mm  
Handle 605 antique silver finish  
centre-to-centre distance 96 mm

### A RICHIESTA ON REQUEST



Maniglia 155 finitura argento anticato  
passo 96 mm  
Handle 155 antique silver finish  
centre-to-centre distance 96 mm

### A RICHIESTA ON REQUEST



Maniglia 606 finitura argento anticato  
passo 96 mm  
Handle 606 antique silver finish  
centre-to-centre distance 96 mm

### A RICHIESTA ON REQUEST



Pomo 435 finitura argento anticato  
Knob hole 435 antique silver finish

### A RICHIESTA ON REQUEST



Maniglia 224 finitura argento antico  
passo 128 mm  
Handle 224 antique silver finish  
centre-to-centre distance 128 mm

### A RICHIESTA ON REQUEST



Pomo 224P finitura argento antico  
utilizzato per elementi da 15  
con maniglia 224  
Knob hole 224P antique silver finish  
used for door W 15 with handle 224

### A RICHIESTA ON REQUEST



Maniglia 251 finitura nichel nero  
satinato lucido  
passo 160 mm  
passo 96 mm per anta L 15  
N.B.: non utilizzare con elementi  
fresati  
Handle 251 polished satin-finish black  
nickel finish centre-to-centre  
distance 160 mm  
centre-to-centre distance 96 mm  
for door W 15  
NOTE: do not use with grooved elements

### A RICHIESTA ON REQUEST



Maniglia 638 finitura ottone anticato  
passo 96 mm  
Handle 638 antique brass finish  
centre-to-centre distance 96 mm

### A RICHIESTA ON REQUEST



Maniglia 157 finitura ottone anticato  
passo 96 mm  
Handle 157 antique brass finish  
centre-to-centre distance 96 mm

### A RICHIESTA ON REQUEST



Pomo 430 finitura ottone antico  
Knob hole 430 antique brass finish

### A RICHIESTA ON REQUEST



Pomo 610B ottone antico  
con formella bianca Knob hole  
610B antique brass finish with white  
tile

### A RICHIESTA ON REQUEST



Pomo 610C ottone antico  
con formella celeste Knob hole  
610C antique brass finish with blue  
tile

### A RICHIESTA ON REQUEST



Pomo 610G ottone antico  
con formella giallo ocra Knob  
hole 610G antique brass finish with  
yellow ochre tile

### A RICHIESTA ON REQUEST



Pomo 610R ottone antico  
con formella grigia Knob hole  
610R antique brass finish with gray  
tile

## MANIGLIE HANDLES

# Agnese

**A RICHIESTA ON REQUEST**



Maniglia 247 finitura nichel lucido con swarovski centrali  
passo 160 mm Handle 247 nickel finish with central swarovski crystals centre-to-centre distance 160 mm

**A RICHIESTA ON REQUEST**



Maniglia 247/1 finitura nichel lucido con swarovski centrali  
passo 32 mm  
utilizzata per elementi da 15 con maniglia 247 Handle 247/1 nickel finish with central swarovski crystals centre-to-centre distance 32 mm used for door W 15 with handle 247

**A RICHIESTA ON REQUEST**



Maniglia 283N finitura nichel lucido con swarovski  
passo 128 mm Handle 283N nickel finish with swarovski crystals centre-to-centre distance 128 mm

**A RICHIESTA ON REQUEST**



Pomo 283NP finitura nichel lucido con swarovski  
utilizzata per elementi da 15 con maniglia 283N Knob hole 283NP nickel finish with swarovski used for door W 15 with handle 283N

**A RICHIESTA ON REQUEST**



Maniglia 282C finitura cromo con swarovski  
passo 128 mm Handle 282C chrome finish with swarovski crystals centre-to-centre distance 128 mm

**A RICHIESTA ON REQUEST**



Pomo 282CP finitura cromo con swarovski  
utilizzata per elementi da 15 con maniglia 282C Knob hole 282CP chrome finish with swarovski crystals used for door W 15 with handle 282C

**A RICHIESTA ON REQUEST**



Maniglia 439 finitura cromo con parte centrale satinata  
passo 128 mm  
Handle 439 chrome finish with satin-finish central part  
centre-to-centre distance 128 mm

**A RICHIESTA ON REQUEST**



Pomo 439P finitura satinata  
utilizzato per elementi da 15 con maniglia 439  
Knob hole 439P satin finish used for 15 W elements with handle 439

**A RICHIESTA ON REQUEST**



Maniglia 521 finitura cromo  
passo 128 mm  
Handle 521 chrome finish  
centre-to-centre distance 128 mm

**A RICHIESTA ON REQUEST**



Pomo 244P finitura cromo  
utilizzato per elementi da 15 con maniglia 521  
Knob hole 244P chrome finish used for 15 W elements with handle 521

**A RICHIESTA ON REQUEST**



Maniglia 522 nei lati finitura cromo interno finitura satinata  
passo 160 mm  
passo 64 mm per anta L 15 Handle 522 chrome finish on sides satin finish on inside  
centre-to-centre distance 160 mm  
centre-to-centre distance 64 mm for door W 15

**A RICHIESTA ON REQUEST**



Maniglia 523 finitura cromo con inserto corda  
passo 160 mm  
passo 64 mm per anta L 15  
Handle 523 chrome finish with rope insert  
centre-to-centre distance 160 mm  
centre-to-centre distance 64 mm for door W 15

**A RICHIESTA ON REQUEST**



Maniglia 524 finitura cromo/satinata  
passo 160 mm  
Handle 524 chrome/satin finish  
centre-to-centre distance 160 mm

**A RICHIESTA ON REQUEST**



Pomo 524P finitura cromo  
passo 16 mm  
utilizzato per elementi da 15 con maniglia 524  
centre-to-centre distance 16 mm  
Knob hole 524P chrome finish used for 15 W elements with handle 524

# Agnese

## strutture carcasses



bianco camelia (opz.606)  
schiena e ripiano avorio (opz.930)  
camellia white (code 606)  
ivory back panel and shelf (code 930)



bianco (opz.001)  
schiena e ripiano bianco (opz.001)  
white (code 001)  
white back panel and shelf (code 001)



celeste agnese (opz.607)  
schiena e ripiano avorio (opz.930)  
blue agnese (code 607)  
ivory back panel and shelf (code 930)



perla d'oriente (opz.940)  
schiena e ripiano avorio (opz.930)  
oriental pearl (code 940)  
ivory back panel and shelf (code 930)



### LUBE ECOLOGIC

IL GRUPPO LUBE HA SCELTO DI UTILIZZARE PER I COMPONENTI COSTITUENTI LE STRUTTURE DELLE CUCINE SOLO MATERIALE A BASSISSIMA EMISSIONE DI FORMALDEIDE: CONFORMI ALLO STANDARD F\*\*\*\* SECONDO LA NORMA JIS, CERTIFICATO DAL MINISTERO GIAPPONESE, IL PIU' SEVERO IN MERITO ALLE NORMATIVE DI SALVAGUARDIA AMBIENTALE.

LUBE GROUP HAS CHOSEN TO EXCLUSIVELY USE MATERIALS WITH VERY LOW FORMALDEHYDE EMISSIONS FOR THE COMPONENTS MAKING UP THE KITCHEN CARCASSES: THESE ELEMENTS COMPLY WITH THE F4 STAR STANDARD ACCORDING TO JIS, CERTIFIED BY THE JAPANESE GOVERNMENT - THE MOST STRINGENT WHEN IT COMES TO ENVIRONMENTAL PROTECTION.

## mensole in laminato laminated shelves



bianco camelia (opz.606)  
camellia white (code 606)



bianco (opz.001)  
white (code 001)



perla d'oriente (opz.940)  
oriental pearl (code 940)

## mensole impiallacciate veneered shelves



impiallacciata come anta  
N.B.: per le finiture vedi colori ante  
veneered same finish as door  
Note: for the finishes see door colours

# Agnese

## zoccoli in pvc H 15 pvc plinths H 15



bianco camelia (opz.606)  
camellia white (code 606)



argilla decapè (opz.599)  
pickled clay grey (code 599)



grigio fumo decapè (opz.603)  
pickled smoke grey (code 603)



bianco (opz.001)  
white (code 001)



celeste agnese (opz.607)  
agnese blue (code 607)

## zoccolo in alluminio H 15 aluminium plinth H 15



alluminio liscio finitura brill (opz.412)  
smooth aluminium with brill finish (code 412)

## cornici cappello top cornices



bianco camelia  
a poro aperto (opz.606)  
camellia white open pore (code 606)



argilla decapè grigio  
a poro aperto (opz.599)  
pickled gray clay open pore  
(code 599)



grigio fumo decapè bianco  
a poro aperto (opz.603)  
gray smoke open pore (code 603)



bianco assoluto  
a poro aperto (opz.609)  
absolute white open pore (code 609)



celeste decapè  
a poro aperto (opz.607)  
pickled blue open pore (code 607)

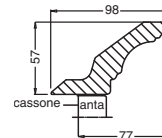

disegno cornice  
design cornice



AGNESE



## APERTURA VERTICALE OBLIQUA **N.B.: per problemi di apertura non affiancare alla colonna**

VERTICAL OPENING OBLIQUE **Note: no problems opening alongside the column**

I pensili con questo tipo di meccanismo necessitano per l'apertura di poco spazio libero sopra il mobile grazie al movimento basculante dell'anta che si apre senza difficoltà applicando poca forza anche in presenza di frontali pesanti. Con l'arresto progressivo le ante si fermano in qualsiasi posizione; in questo modo la maniglia è sempre facilmente raggiungibile. La chiusura è ammortizzata ed è possibile regolare la forza di tenuta in base al peso del frontale.

Wall units that mount this type of mechanism require little clearance above the cabinet thanks to the swivelling movement of the door that can be easily opened by applying slight pressure, even with heavy fronts. The doors stop in any position thanks to the gradual stopping movement; in this way, the handle is always easily accessible. The closing movement is cushioned and the closing force can be adjusted according to the weight of the front door.

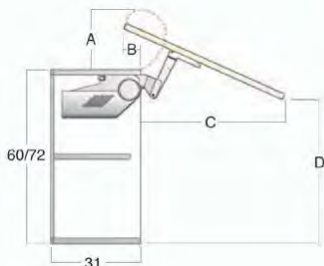

	A	B	C	D
H 60	18	9,6	46,5	53,5
H 72	18	9,6	57	61

## APERTURA VERTICALE

VERTICAL OPENING

L'anta ad apertura verticale, potendo essere sollevata completamente verso l'alto, consente un accesso totale all'interno del pensile.

Ideale per l'impiego in mobili a colonna per nascondere ad esempio apparecchi elettrici, o pensili con corpi mobili sovrastanti, ha la chiusura ammortizzata e la possibilità di regolare la forza di tenuta in base al peso del frontale.

Doors with vertical opening movement can be fully raised to fully access the inside of the wall unit. Ideal for use on column units to conceal electrical appliances, for example, or on wall units surmounted by mobile units. The closing movement is cushioned and the closing force can be adjusted according to the weight of the front.

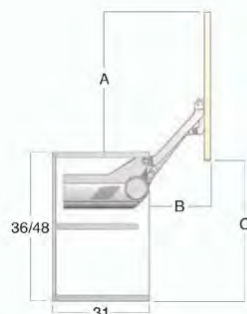

	A	B	C	
H 36	34	23,5	34,5	
H 48	43	28,5	43,5	

## PENSILE CON APERTURA ANTE A PACCHETTO

WALL UNIT WITH LIFT-UP FOLDING DOOR

Il meccanismo d'apertura ante a pacchetto è idoneo sia sul pensile H 72 che H 96; la regolazione della forza di apertura può essere impostata in modo esatto in base ai pesi dei frontali, la chiusura è ammortizzata e la cerniera centrale clip si contraddistingue per l'innovativa tecnologia che garantisce la sicurezza per le dita.

The lift-up folding door opening mechanism is suitable for wall units with H 72 or H 96; the opening force can be adjusted precisely according to the weight of the fronts, while the closing movement is cushioned and the central clip-on hinge features innovative technology for safeguarding the fingers



H 72



H 96

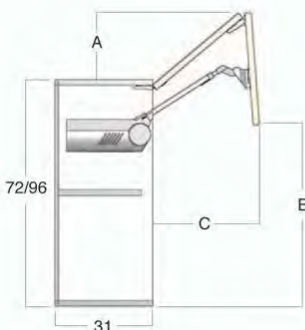

	A	B	C	
H 72	16,5	54	41	
H 96	20	69	53	

Per evitare l'interferenza dell'anta in fase di apertura con cornici o mensole, si può richiedere il limitatore dell'angolo di apertura cod.5620005 € 10

In order to avoid that door interferes with cornices or shelves during the opening movement, it is possible to request an opening angle limiter: cod.5620005 € 10

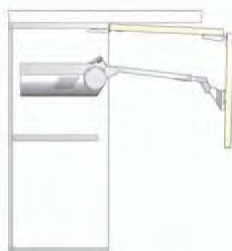

### SCHEMA MONTAGGIO DEL LIMITATORE LIMITER INSTALLATION DIAGRAM

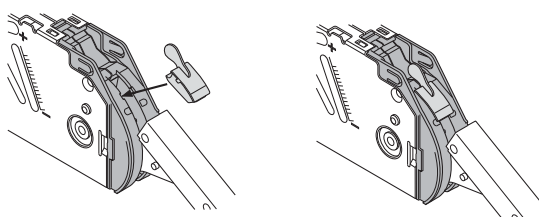



# PENSILE CON APERTURA A RIBALTA

WALL UNIT WITH FLAP DOOR

Le ante aprendosi verso l'alto consentono di avere un'ampia visione d'insieme all'interno del mobile. In questo modo è possibile un comodo accesso agli oggetti contenuti al suo interno e, dal punto di vista ergonomico, molto vantaggioso. La regolazione della forza di apertura può essere impostata in modo esatto in base al peso del frontale. Grazie all'arresto progressivo le ante si fermano in qualsiasi posizione; in questo modo la maniglia è sempre facilmente raggiungibile. La chiusura è ammortizzata e un'unica manovra è sufficiente per regolare il frontale tridimensionalmente grazie all'assenza di cerniere e al sistema di aggancio clip.

The door that open upwards guarantee ample overall visibility inside the cabinet. In this way, all objects housed inside the cabinet can be comfortably accessed, making the system highly advantageous from an ergonomic perspective. The opening force can be adjusted precisely depending on the weight of the front. The doors stop in any position thanks to the gradual stopping movement; in this way, the handle is always easily accessible. The closing movement is cushioned and a single manoeuvre is required to three-dimensionally adjust the front, thanks to the clip-on system and the absence of hinges.

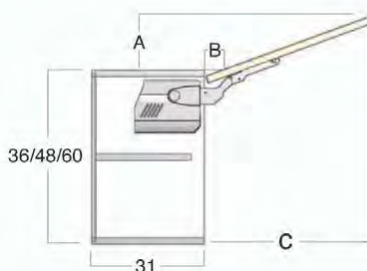

	A	B	C	
H 36	11,5	3,5	37	
H 48	15	3,5	49	
H 60	18,5	3,5	61	

Per evitare l'interferenza dell'anta in fase di apertura con cornici o mensole si può richiedere il limitatore dell'angolo di apertura cod.5620010 € 10

In order to avoid that the door interferes with cornices or shelves during the opening movement, it is possible to request an opening angle limiter: cod.5620010 € 10

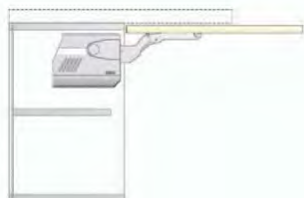

## SCHEMA MONTAGGIO LIMITATORE PER RIBALTA H 36

FLAP DOOR LIMITER  
INSTALLATION DIAGRAM H 36

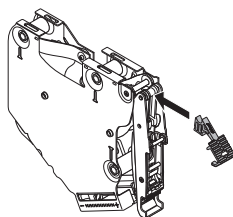

## SCHEMA MONTAGGIO LIMITATORE PER RIBALTA H 48

FLAP DOOR LIMITER  
INSTALLATION DIAGRAM H 48

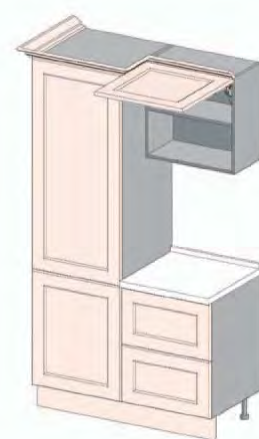
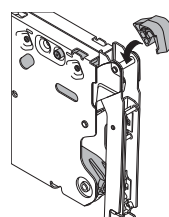

## TIPOLOGIE CAPPE CAMINO

HOOD CHIMNEY TYPES

### cappa fascione tipo "A" camino bucciato bianco vedi pag.66

band hood type "A"  
white textured chimney hood  
see page 66



### cappa fascione tipo "A" camino in tinta come anta con fresate vedi pag.68

band hood type "A"  
chimney hood to match door with grooves  
see page 68



### cappa fascione tipo "B" camino bucciato bianco vedi pag.70

band hood type "B"  
white textured chimney hood  
see page 70



### cappa fascione tipo "B" camino in tinta come anta con fresate vedi pag.72

band hood type "B"  
chimney hood to match door with grooves  
see page 72



## TIPOLOGIE CAPPE CAMINO

HOOD CHIMNEY TYPES

### cappa fascione tipo "C" camino bucciato come anta vedi pag.74

band hood type "C"

textured chimney hood to match door

see page 74



### cappa fascione tipo "C" camino in tinta come anta con fresate vedi pag.76

band hood type "C"

chimney hood to match door with grooves

see page 76



### cappa fascione tipo "D" camino bucciato bianco vedi pag.78

band hood type "D"

white textured chimney hood

see page 78



### cappa fascione tipo "D" camino in tinta come anta con fresate vedi pag.80

band hood type "D"

chimney hood to match door with grooves

see page 80



## TIPOLOGIE CAPPE

HOOD TYPES

### cappa tipo "E" vedi pag.82

type "E" hood  
see page 82



### cappa isola vedi pag.84

island hood  
see page 84



### cappa tipo "P2" vedi pag.85

type "P2" hood  
see page 85



### cappa isola con piastrelle vedi pag.84

island hood with tiles  
see page 84



# SCHEMA CAPPA CAMINETTO AD ANGOLO

DIAGRAM OF CORNER CHIMNEY HOOD

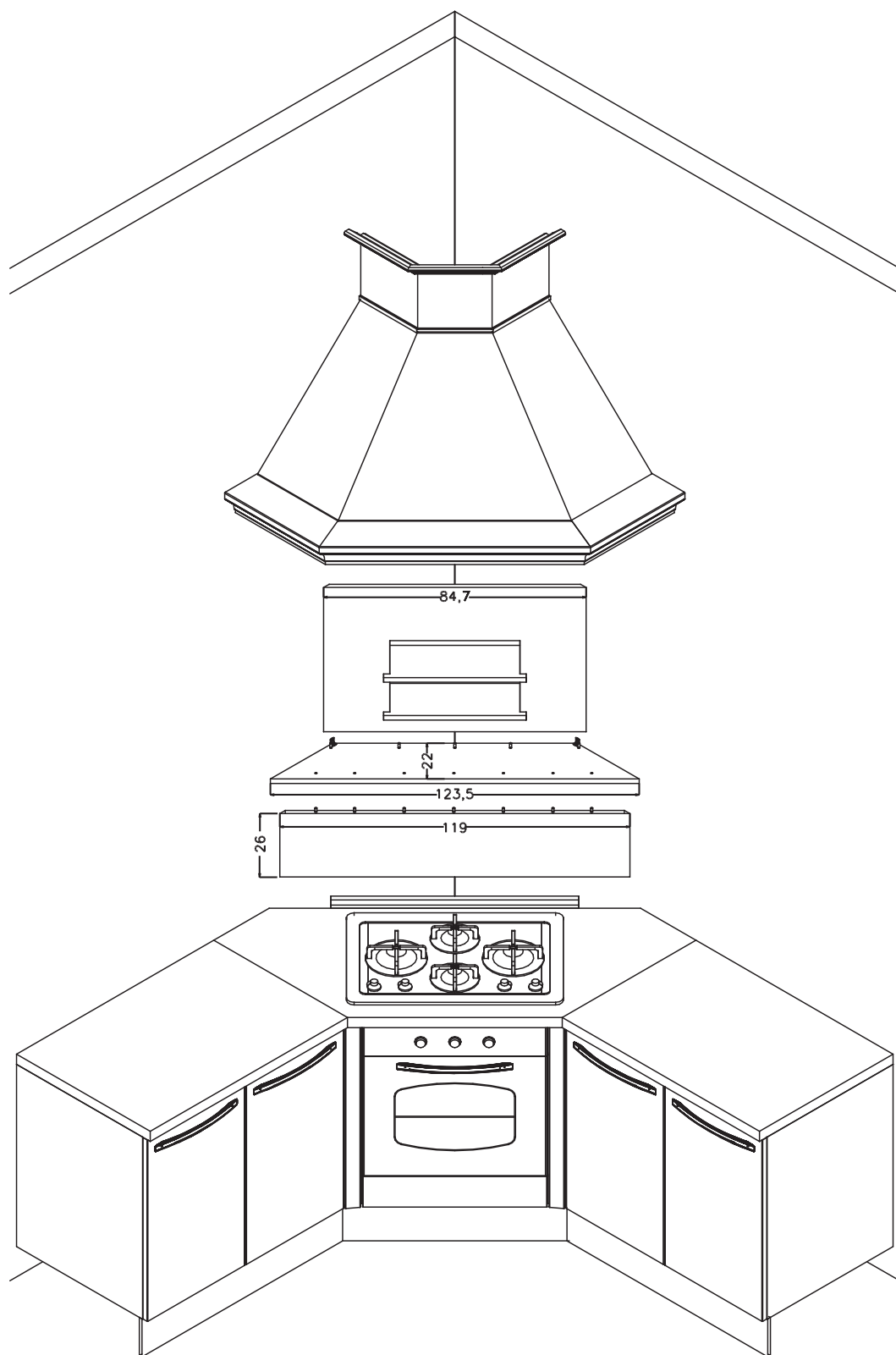



# SCHEMA CAPPA CAMINETTO AD ANGOLO

DIAGRAM OF CORNER CHIMNEY HOOD

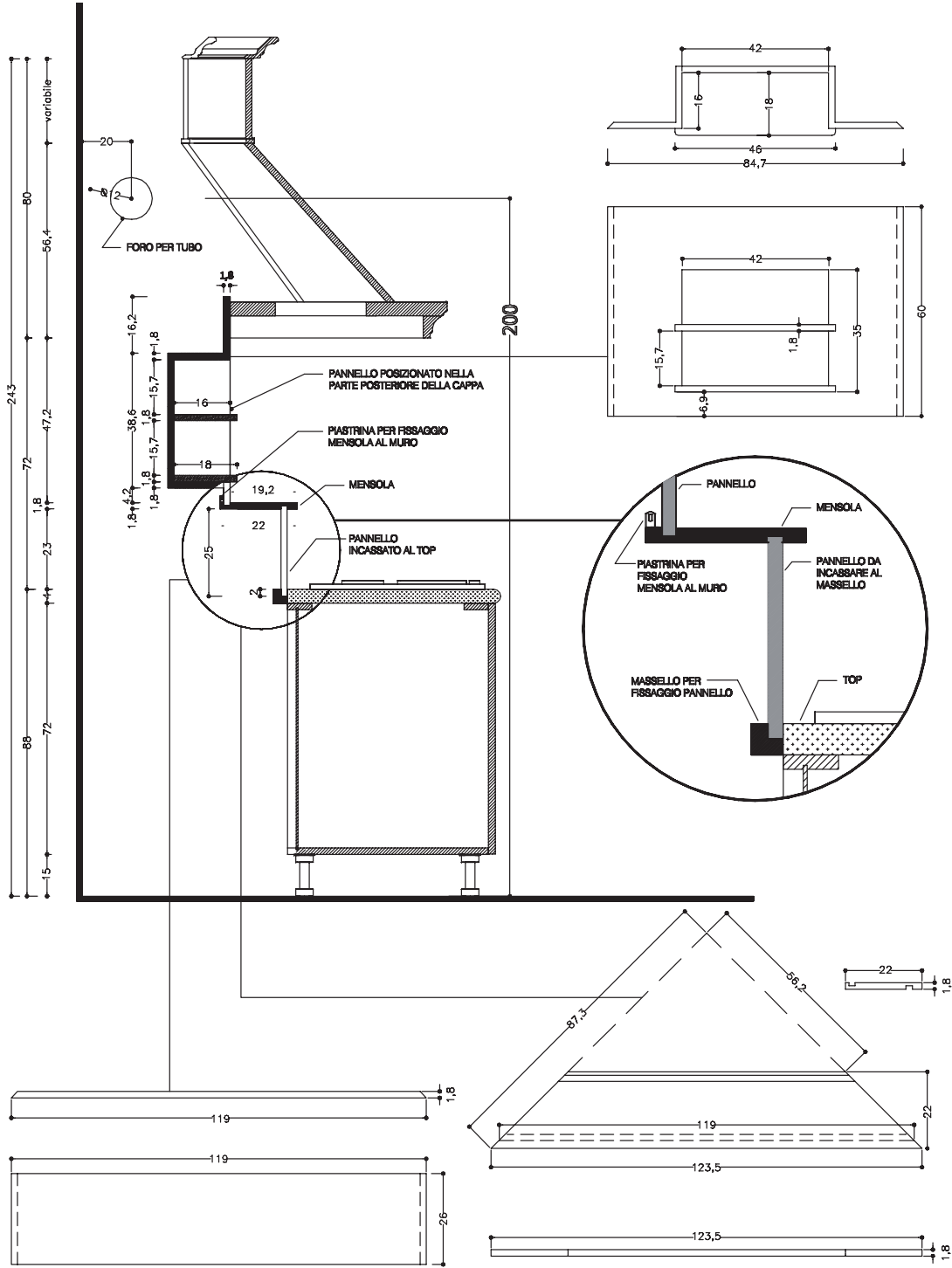

# RILEVAZIONE DEL FUORI SQUADRO

OUT-OF-PLUMB MEASUREMENTS

Per le composizioni ad angolo è importante rilevare l'esatta misura dell'angolo per il corretto montaggio della cucina.

Si tenga presente che la diagonale dell'angolo di 90° è di cm 141,4 (100x100).

For corner compositions, it is important to measure the corner precisely to ensure that the kitchen is correctly installed.

Bear in mind that diagonal segment opposite the 90° corner measures 141,4 (100x100)

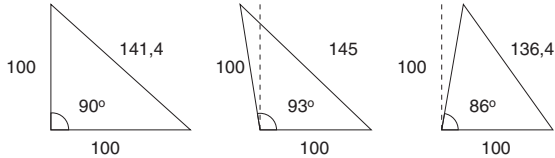

Riportiamo di seguito una tabella in cui sono riportate rispettivamente la misura dell'angolo con la diagonale corrispondente.

Below is a table indicating, respectively, the size of the corner and the length of the corresponding diagonal segment

## ANGOLI SUPERIORI A 90°

CORNERS EXCEEDING 90°

angolo in gradi corner in degrees	diagonale in cm diagonal segment in cm
90	141,4
90,5	142
91	142,6
91,5	143,3
92	143,9
92,5	144,5
93	145
93,5	145,7
94	146,3
94,5	146,9
95	147,4
95,5	148
96	148,6
96,5	149,2
97	149,8
97,5	150,4
98	150,9
98,5	151,5
99	152,1
99,5	152,6
100	153,2

## ANGOLI INFERIORI A 90°

CORNERS BELOW 90°

angolo in gradi corner in degrees	diagonale in cm diagonal segment in cm	aumento in cm della composizione increase in cm of the composition
90	141,4	-
89,5	140,8	-
89	140,2	-
88,5	139,5	-
88	138,9	-
87,5	138,3	-
87	137,7	-
86,5	137	-
86	136,4	-
85,5	135,8	1,5
85	135,1	2
84,5	134,5	2,5
84	133,8	3
83,5	133,2	3,5
83	132,5	4,5
82,5	131,9	5
82	131,2	6
81,5	130,5	6,5
81	129,9	8
80,5	129,2	8,5
80	128,5	9,5
79,5	127,9	10
79	127,2	10,5
78,5	126,5	11,5
78	125,8	12
77,5	125,2	12,5
77	124,5	13,5

## ANGOLO MAGGIORE DI 90° CORNER EXCEEDING 90°

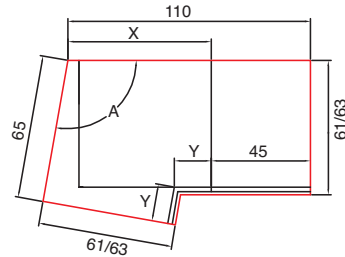

Nel caso in cui abbiamo un angolo maggiore di 90° le misure della base ad angolo non cambiano, ma viene aumentata la misura del massello angolare (Y).

N.B. per angoli maggiori di 110° interpellare sempre il nostro Ufficio Tecnico.

In case of corners exceeding 90°, the dimensions of the corner base unit do not change, while the size of the corner solid wood section (y) increases.

Note: for corners exceeding 110°, always contact our Technical Department.

## ANGOLO COMPRESO TRA 86° E 90° CORNER BETWEEN 86° AND 90°

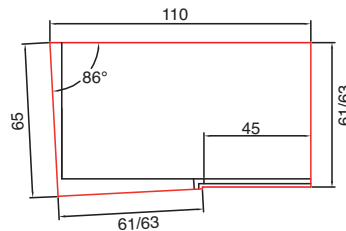

Nel caso in cui abbiamo un angolo compreso tra 86° e 90° le misure della base ad angolo non cambiano, ma viene diminuita la misura del massello angolare (Y).

Inoltre è necessario tener presente che di seguito alla base ad angolo non possono essere inserite basi forno, cassettiere, lavastoviglie, ma esclusivamente basi con anta incernierata sul fianco.

In case of corners between 86° and 90°, the dimensions of the corner base unit do not change, while the size of the corner solid wood section (y) decreases. Moreover, it is important to remember that oven base units, drawer units or dish-washers cannot be inserted next to the corner base unit, but only base units that have the door hinges on the side.

## ANGOLO MINORE DI 86° CORNER BELOW 86°

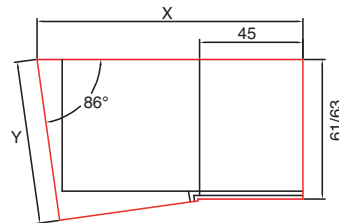

Quando l'angolo è inferiore a 86° la lunghezza della composizione viene aumentata in rapporto all'ampiezza dell'angolo (vedi tabella) per questo motivo è importante specificare nell'ordine le misure delle pareti da arredare.

Inoltre è necessario tener presente che di seguito alla base ad angolo non possono essere inserite basi forno, cassettiere, lavastoviglie, ma esclusivamente basi con anta incernierata sul fianco.

When the corner measures below 86°, the length of the composition increases in relation to the size of the corner (see table); for this reason, in the order it is important to specify the measurements of the walls to be furnished. Moreover, it is important to remember that oven base unit, drawer units or dish-washers cannot be inserted next to the corner base unit, but only base units that have the door hinges on the side.

# RILEVAZIONE DEL FUORI SQUADRO

OUT-OF-PLUMB MEASUREMENTS

Nelle composizioni lineari dove a inizio o fine composizione c'è una parete fuori squadra prendere sempre la misura della diagonale e comunicarla al nostro Ufficio Tecnico.

In regards to linear compositions that have an out-of-plumb wall at the beginning or end of the composition, remember to always take the measurement of the diagonal segment and notify it to our Technical Department.

Nell'esempio n. 1 l'angolo è maggiore di  $90^\circ$  e quindi occorre aumentare il top davanti; la stessa cosa si deve fare per le basi, mettendo una fascia di tamponamento.

In example no.1, the corner exceeds  $90^\circ$ , thus the worktop must be extended on the front; the same applies to base units, where a filler panel must be added.

Nell'esempio n. 2 l'angolo è minore di  $90^\circ$  occorre accorciare la composizione; questo vale sia per il top che per le basi.

In example no.2, the corner is below  $90^\circ$ , therefore the composition must be shortened; this applies to both the worktop and base units.

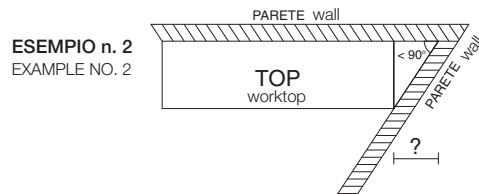
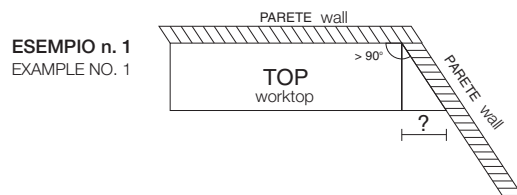

Nel caso in cui nell'angolo ci sia un pilastro, occorre inviare una sagoma al nostro Ufficio Tecnico, soprattutto quando si è in presenza di angoli rovesci.

If the corner contains a pilaster, a template of the latter must be sent to our Technical Department, especially in case of inverted angles.

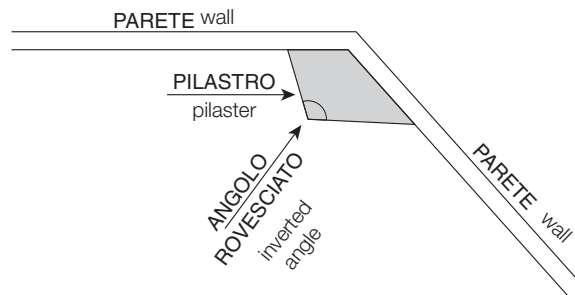

# SCHEMA BASI E TOP TERMINALI

DIAGRAMS OF END BASE UNITS AND WORKTOPS

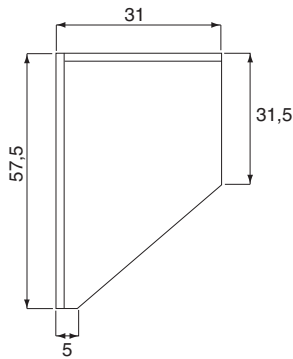

**BASE TERMINALE a giorno tipo "C"**  
Type "C"  
open END BASE UNIT

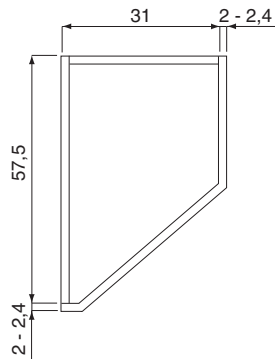

**BASE TERMINALE con anta tipo "C"**  
END BASE UNIT  
with type "C" door

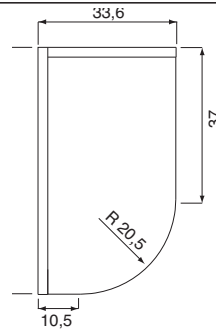

**BASE TERMINALE stondata a giorno**  
open END BASE UNIT  
rounded

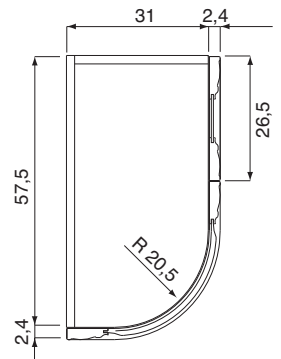

**BASE TERMINALE stondata con anta**  
open END BASE UNIT  
with curved door

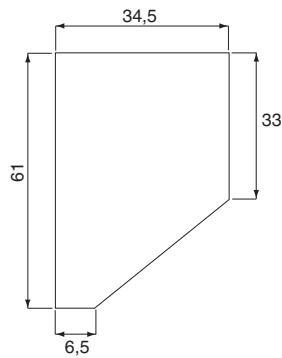

**TOP PER BASE TERMINALE a giorno tipo "C"**  
WORKTOP FOR type "C"  
open END BASE UNIT

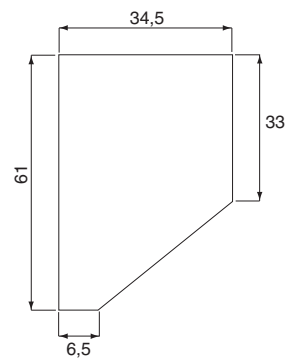

**TOP PER BASE TERMINALE con anta tipo "C"**  
WORKTOP FOR END BASE UNIT  
with type "C" door

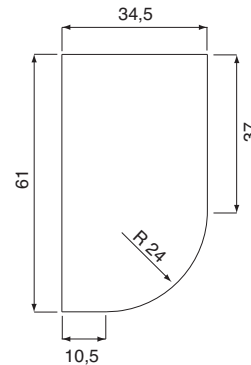

**TOP PER BASE TERMINALE stondata a giorno**  
WORKTOP FOR END BASE UNIT  
open rounded

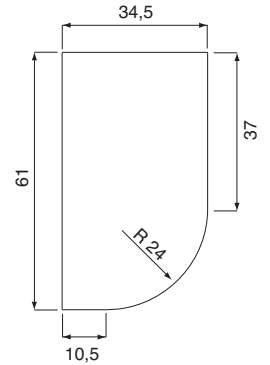

**TOP PER BASE TERMINALE stondata con anta**  
WORKTOP FOR END BASE UNIT  
open with curved door

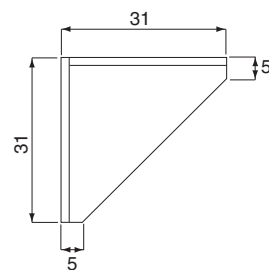

**PENSILE TERMINALE a giorno tipo "C"**  
Type "C"  
open END WALL UNIT

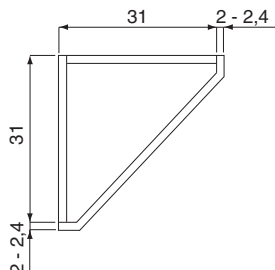

**PENSILE TERMINALE con anta tipo "C"**  
END WALL UNIT  
with type "C" door

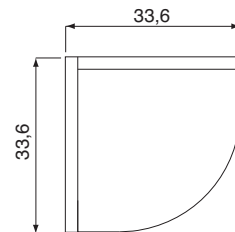

**PENSILE TERMINALE stondata a giorno**  
open END WALL UNIT  
rounded

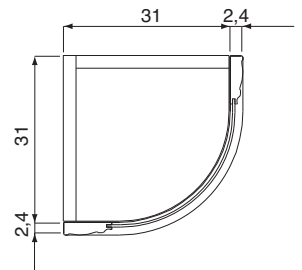

**PENSILE TERMINALE stondata con anta**  
END WALL UNIT  
with curved door

# INFORMAZIONI TECNICHE

TECHNICAL INFORMATION

## POSIZIONAMENTO BARRA PER FISSAGGIO PENSILI

POSITIONING OF THE WALL UNIT FIXING STRIP

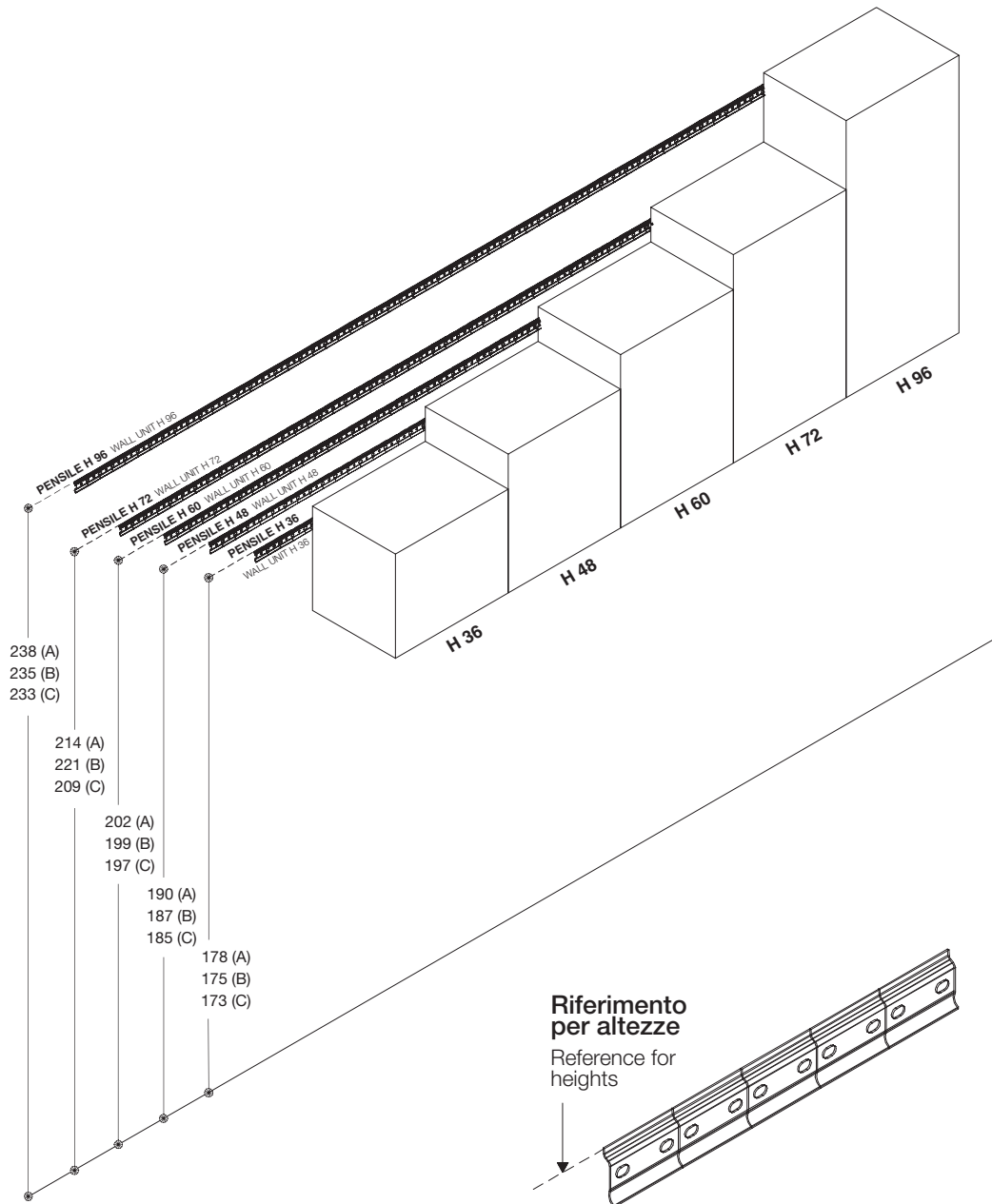

**(A) Zoccolo H 15**

(A) Plinth H 15

**(B) Zoccolo H 12**

(B) Plinth H 12

**(C) Zoccolo H 10**

(C) Plinth H 10

**N.B.: in prossimità dell'attaccaglia, mettere minimo 2 fischer vicini, per dare una maggiore tenuta**

Note: place at least 2 rawl plugs close together near fixing elements to increase the load bearing capacity

# SCHEMA DI ALLACCIO IMPIANTO ELETTRICO IDRICO E GAS

POWER, WATER AND GAS NETWORKS CONNECTIONS DIAGRAM

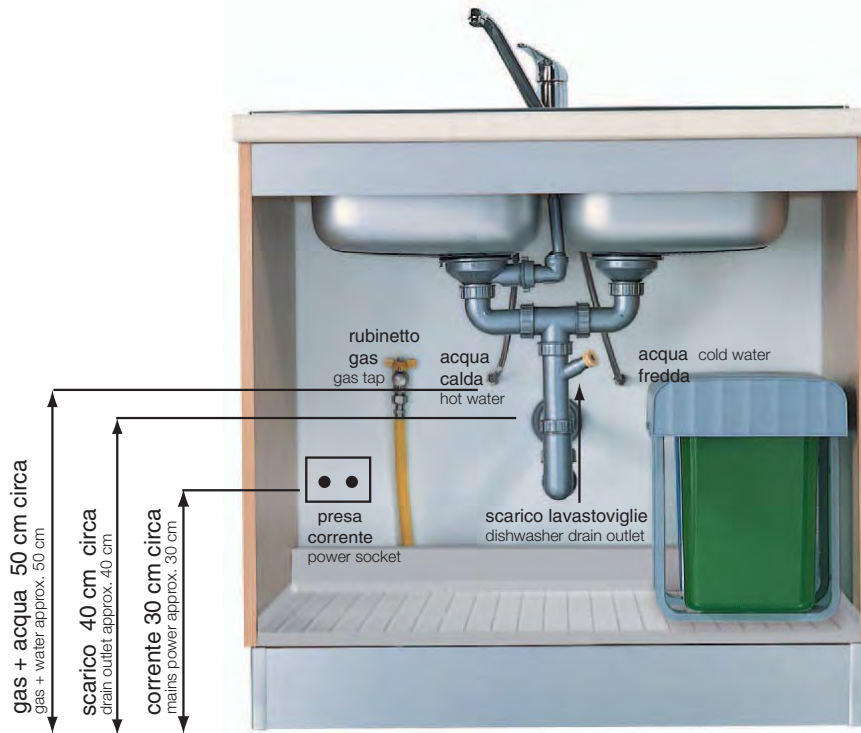

**SOTTOLAVELLO CON ANTE**  
SINK BASE UNIT WITH DOORS

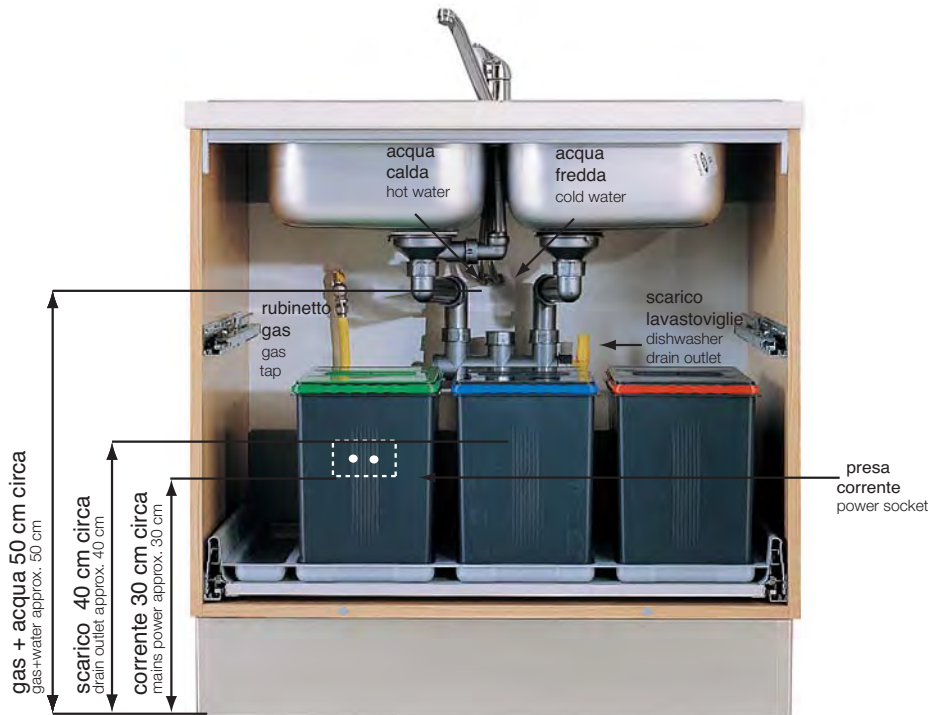

**SOTTOLAVELLO 2 CESTONI CON SIFONE SALVASPAZIO**  
SINK BASE UNIT WITH 2 DEEP DRAWERS AND SPACE-SAVER DRAIN PIPING

## INFORMAZIONI PER LA PROGETTAZIONE

DESIGN INFORMATION

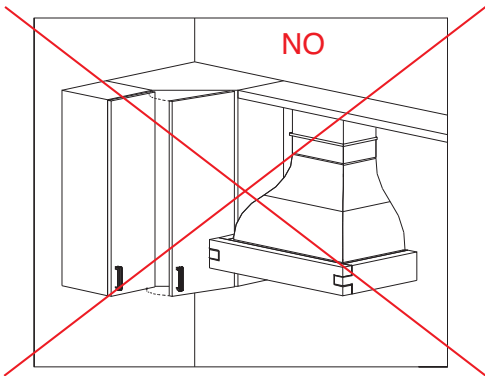

### CAPPA A RIDOSSO DEL PENSILE ANGOLO HOOD ADJACENT TO CORNER WALL UNIT

**Consigliamo di non posizionare una cappa d'arredamento a fianco di un pensile angolo 65x65 diagonale in quanto impedisce la corretta apertura dell'anta.**

It is advisable not to install a design hood adjacent to a 65x65 cm diagonal corner wall unit, as this interferes with the opening of the wall unit door.

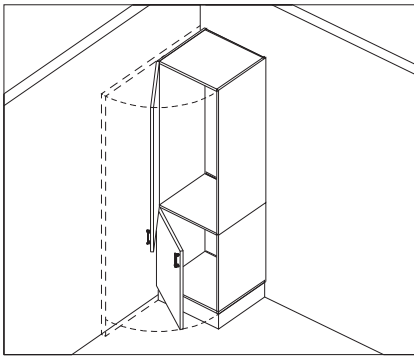

### FRIGORIFERO VICINO AL MURO REFRIGERATOR NEAR THE WALL

**Nel caso che una colonna frigorifero sia posizionata vicino ad una parete occorre lasciare uno spazio di almeno 4 cm per consentire una totale apertura dell'anta della colonna e l'estrazione totale dei cassetti dell'elettrodomestico.**

If a fridge column is positioned close to a wall, leave at least 4 cm free to ensure the full opening of the column door and the full extension of the appliance's drawers.

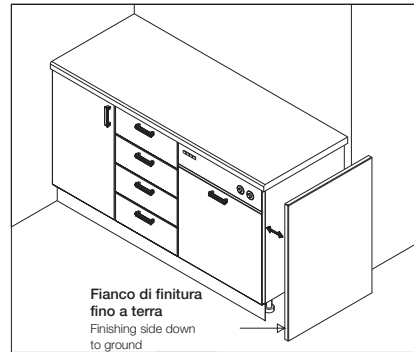

### ELETTRODOMESTICO A FINE COMPOSIZIONE HOUSEHOLD APPLIANCE AT THE END OF A COMPOSITION

**Nel caso che la lavastoviglie o la lavatrice sia posizionata a fine composizione occorre l'uso di un fianco di finitura fino a terra, considerando lo spessore dello stesso per determinare la lunghezza del top.**

If a dishwasher or washing machine is placed at the end of a composition, it is necessary to install a finishing side down to ground; the latter's thickness must be considered when determining the length of the worktop.

## INFORMAZIONI PER LA PROGETTAZIONE

DESIGN INFORMATION

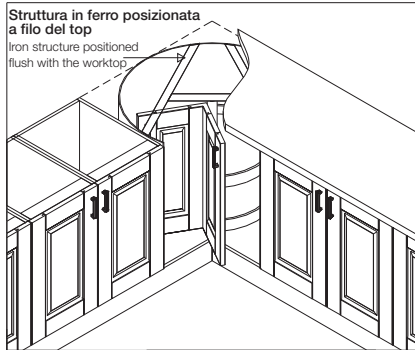

### BASE ANGOLO 95x95 2 ANTE GIREVOLI 95x95 CORNER BASE UNIT WITH 2 SWIVEL DOORS

**Non è possibile inserire gli elettrodomestici.**  
Household appliances cannot be inserted

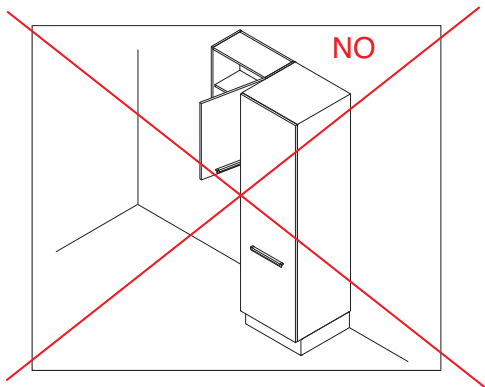

### PENSILE ACCANTO ALLA COLONNA WALL UNIT NEXT TO A COLUMN

**Evitare il posizionamento del pensile verso la colonna, in quanto non si ha una completa apertura dell'anta e si rischia di danneggiare il fianco.**

Avoid placing a wall unit near the column, as this prevents the complete opening of the door and may cause the side to be damaged

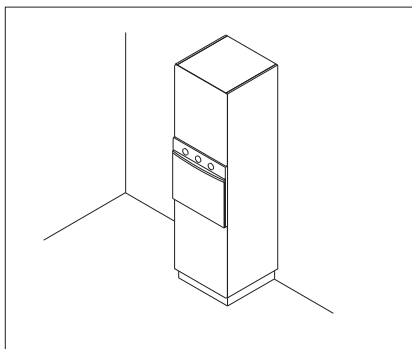

### FORNI STATICI SENZA VENTILAZIONE NON-VENTILATED STATIC OVENS

**Evitare l'abbinamento dei forni statici senza ventilazione di raffreddamento nelle colonne, poiché il calore e il vapore emanati durante il funzionamento dell'elettrodomestico possono danneggiare le antine e la struttura della colonna.**

Avoid inserting non-ventilated static ovens in columns, as the heat and steam generated during the appliance's operation may damage the column's doors and carcass.

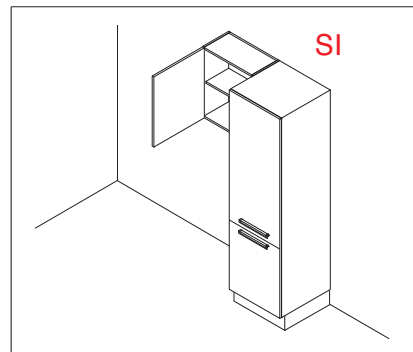

**Si consiglia di utilizzare il pensile con l'apertura dell'anta opposta alla posizione della colonna con cerniere a 180°**

It is advisable to use a wall unit with a door that opens in the opposite direction to the column's position, with 180° hinges.

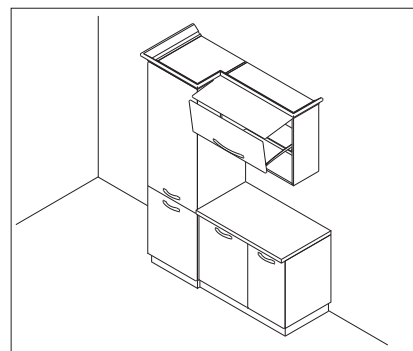

### PENSILE A PACCHETTO WALL UNIT WITH LIFT-UP FOLDING DOOR

**Per evitare nei pensili con apertura a pacchetto l'interferenza dell'anta in fase di apertura con cornici o mensole si può richiedere il limitatore dell'angolo di apertura cod.5620005 € 10**

In order to avoid that the lift-up folding door interferes with cornices or shelves during the opening movement, it is possible to request an opening angle limiter code 5620005 € 10



# MODULARITÀ E COMPONIBILITÀ

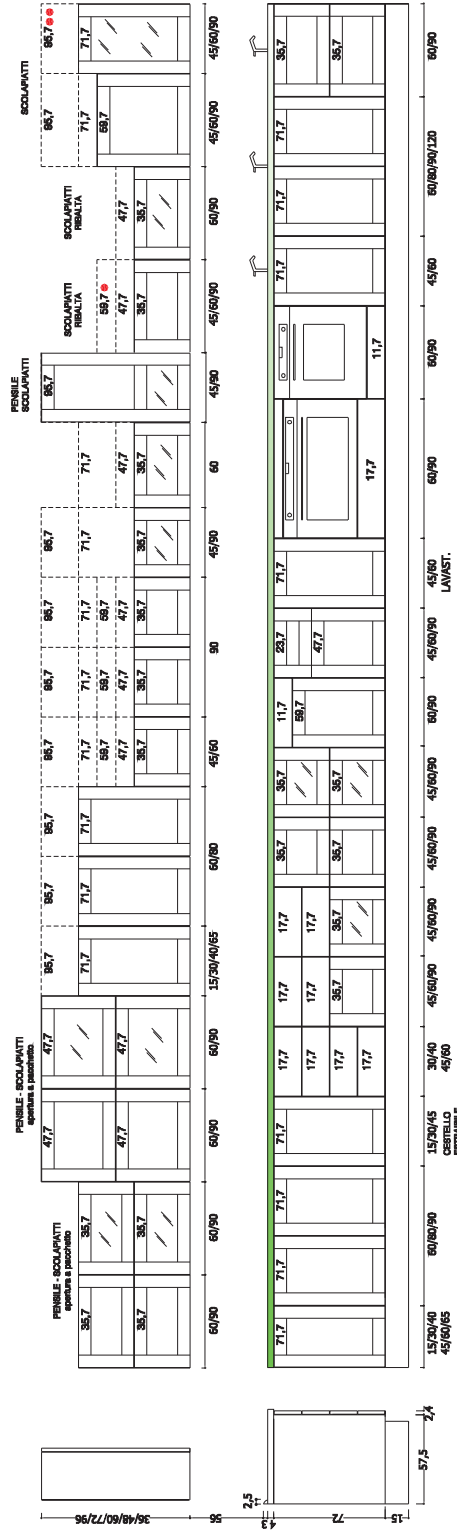

\* SOLI 60/90 ● ESCLUSO 90 ●● ESCLUSO 60

## BASI H 75 RIBASSATE

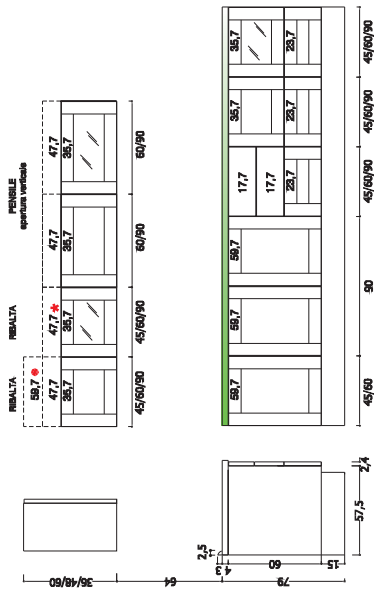

## BASI SOSEPE

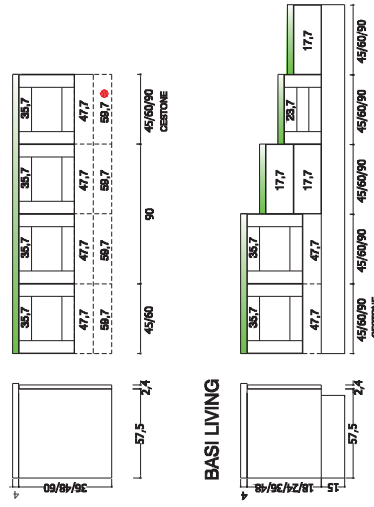

## BASI LIVING

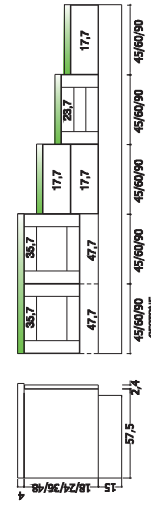



# MODULARITÀ E COMPONENTABILITÀ

AGNESE

